

GÜHROJET reduction sleeves for hydraulic chucks with peripheral cooling

Product information

- for clamping smaller shank-Ø in hydraulic chucks
- clamping-Ø for tool shank tolerance h6
- with coolant slots for peripheral cooling, therefore process and tool life improvement
- concentricity $\leq 2 \mu\text{m}$
- with adjustable limit stop
- the application of reduction sleeves makes it possible to increase the permissible transferable torque by approx. 25% in comparison to direct clamping

Scope of delivery

- incl. stop element
- special dimensions on request

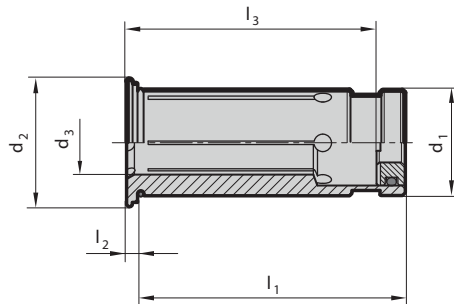

GÜHROJET

Series Number **4369**

d_1 inch/mm	for shank Ø $d_{3\ h6}$ inch/mm	d_2 mm	l_1 mm	l_2 mm	l_3 mm	Order Code	EDP Numbers
1/2	1/8	16.5	45	2	26.5	3.013	9043690030130
1/2	3/16	16.5	45	2	26.5	4.013	9043690040130
1/2	1/4	16.5	45	2	26.5	6.013	9043690060130
1/2	5/16	16.5	45	2	26.5	8.013	9043690080130
1/2	3/8	16.5	45	2	26.5	9.013	9043690090130
3/4	1/8	24	50.5	2	28.5	3.019	9043690030190
3/4	3/16	24	50.5	2	28.5	4.019	9043690040190
3/4	1/4	24	50.5	2	37.5	6.019	9043690060190
3/4	5/16	24	50.5	2	37.5	8.019	9043690080190
3/4	3/8	24	50.5	2	42.5	9.019	9043690090190
3/4	7/16	24	50.5	2	42.5	11.019	9043690110190
3/4	1/2	24	50.5	2	47.5	13.019	9043690130190
3/4	9/16	24	50.5	2	47.5	14.019	9043690140190
3/4	5/8	24	50.5	2	47.5	15.019	9043690150190
1 1/4	1/4	35.5	60.5	2	37.5	6.031	9043690060310
1 1/4	5/16	35.5	60.5	2	37.5	8.031	9043690080310
1 1/4	3/8	35.5	60.5	2	37.5	9.031	9043690090310
1 1/4	1/2	35.5	60.5	2	44.5	13.031	9043690130310
1 1/4	9/16	35.5	60.5	2	44.5	14.031	9043690140310
1 1/4	5/8	35.5	60.5	2	50.5	15.031	9043690150310
1 1/4	11/16	35.5	60.5	2	50.5	17.031	9043690170310
1 1/4	3/4	35.5	60.5	2	50.5	19.031	9043690190310
1 1/4	7/8	35.5	60.5	2	50.5	22.031	9043690220310
1 1/4	1	35.5	60.5	2	58.5	25.031	9043690250310
1/2	5	16.5	45	2	26.5	105.013	9043691050130
1/2	6	16.5	45	2	26.5	106.013	9043691060130
3/4	3	24	50.5	2	28.5	103.019	9043691030190
3/4	4	24	50.5	2	28.5	104.019	9043691040190
3/4	6	24	50.5	2	37.5	106.019	9043691060190
3/4	8	24	50.5	2	37.5	108.019	9043691080190
3/4	10	24	50.5	2	42.5	110.019	9043691100190
3/4	12	24	50.5	2	47.5	112.019	9043691120190
3/4	14	24	50.5	2	47.5	114.019	9043691140190
1 1/4	20	35.5	60.5	2	50.5	120.031	9043691200310
1 1/4	25	35.5	60.5	2	58.5	125.031	9043691250310
12	1/8	16.5	45	2	26.5	103.012	9043691030120
12	3/16	16.5	45	2	26.5	104.012	9043691040120
12	1/4	16.5	45	2	34.5	106.012	9043691060120
12	5/16	16.5	45	2	34.5	108.012	9043691080120
12	3/8	16.5	45	2	34.5	109.012	9043691090120