

ISO taper shrink fit chucks

Product information

- balancing quality G6.3 / 15,000 rev./min
- incl. balancing thread 4xM6/6xM6
- ISO taper to DIN 69871 form AD/B
- for tool shank tolerance h6
- also available in the lengths l1 = 120 mm, 160 mm (concentricity 5 µm) and 200mm (concentricity 7 µm)

Scope of delivery

- incl. setting screw Guhring no. 4977 bzw. 4904
- order pull studs Guhring no. 4925, 4926 separately
- special dimensions on request

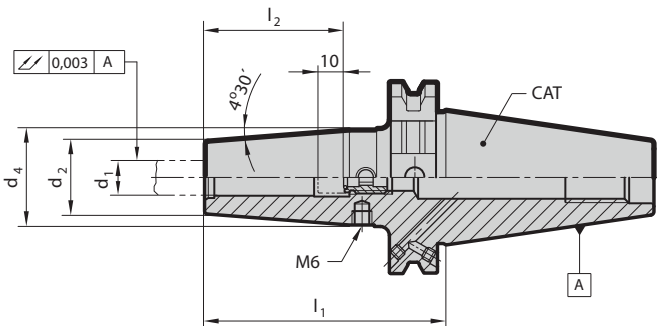

Series Number

4738

ISO taper	for shank Ø d _{1 h6} mm	d ₂ mm	d ₄ mm	l ₁ mm	l ₂ mm	incl. setting screw Guh. no. Code no.	kg	Order Code	EDP Numbers
40	3	10	18	80	30	9049040050160	0.90	3.040	9047380030400
40	4	10	18	80	35	9049040060160	0.90	4.040	9047380040400
40	5	10	18	80	40	9049040080180	0.90	5.040	9047380050400
40	6	21	27	80	36	9049770060140	1.00	6.040	9047380060400
40	8	21	27	80	36	9049770080140	1.00	8.040	9047380080400
40	10	24	32	80	41	9049770100140	1.10	10.040	9047380100400
40	12	24	32	80	46	9049770120140	1.00	12.040	9047380120400
40	14	27	34	80	46	9049770120140	1.10	14.040	9047380140400
40	16	27	34	80	49	9049770160140	1.10	16.040	9047380160400
40	18	33	42	80	49	9049770160140	1.20	18.040	9047380180400
40	20	33	42	80	51	9049770201140	1.50	20.040	9047380200400
40	25	44	53	100	57	9049770201140	1.50	25.040	9047380250400
40	32	44	53	100	61	9049770201140	1.50	32.040	9047380320400
40	3	10	24	120	30	9049040050160	1.00	203.040	9047382030400
40	4	10	24	120	35	9049040060160	1.00	204.040	9047382040400
40	5	10	24	120	40	9049040080180	1.00	205.040	9047382050400
40	6	21	27	120	36	9049770060140	1.10	206.040	9047382060400
40	8	21	27	120	36	9049770080140	1.10	208.040	9047382080400
40	10	24	32	120	41	9049770100140	1.20	210.040	9047382100400
40	12	24	32	120	46	9049770120140	1.20	212.040	9047382120400
40	14	27	34	120	46	9049770120140	1.40	214.040	9047382140400
40	16	27	34	120	49	9049770160140	1.40	216.040	9047382160400
40	18	33	42	120	49	9049770160140	1.50	218.040	9047382180400
40	20	33	42	120	51	9049770201140	1.50	220.040	9047382200400
40	3	10	31	160	30	9049040050160	1.10	103.040	9047381030400
40	4	10	31	160	35	9049040060160	1.10	104.040	9047381040400
40	5	10	31	160	40	9049040080180	1.10	105.040	9047381050400
40	6	21	27	160	36	9049770060140	1.30	106.040	9047381060400
40	8	21	27	160	36	9049770080140	1.30	108.040	9047381080400
40	10	24	32	160	41	9049770100140	1.50	110.040	9047381100400
40	12	24	32	160	46	9049770120140	1.50	112.040	9047381120400
40	14	27	34	160	46	9049770120140	1.70	114.040	9047381140400
40	16	27	34	160	49	9049770160140	1.70	116.040	9047381160400
40	18	33	42	160	49	9049770160140	1.90	118.040	9047381180400
40	20	33	42	160	51	9049770201140	1.90	120.040	9047381200400
40	25	44	53	160	57	9049770201140	2.20	125.040	9047381250400
40	6	21	27	200	36	9049770060140	1.60	306.040	9047383060400
40	8	21	27	200	36	9049770080140	1.60	308.040	9047383080400
40	10	24	32	200	41	9049770100140	1.80	310.040	9047383100400
40	12	24	32	200	46	9049770120140	1.80	312.040	9047383120400
40	14	27	34	200	46	9049770120140	2.10	314.040	9047383140400