

FRACTIONAL

# RF 100 A/WF 3-Flute

Variable helix, Rougher, bright finish

Includes Series

INCH

4266



TYPE	<b>WF</b>
HELIX ANGLE	29° 30° 31°
NUMBER of TEETH	<b>3</b>

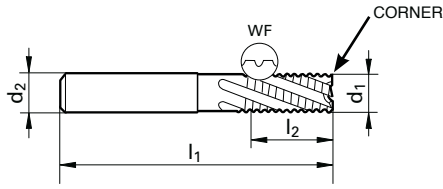

d<sub>1</sub> tolerance h10  
d<sub>2</sub> tolerance h6  
See table on page 150



Diameter	Shank Diameter	OAL	LOC	Corner	HA		HB	
					EDP No.	Series Number	EDP No.	Series Number
1/4	1/4	2 1/2	3/4	0.012	9042660063500	4266		
5/16	5/16	2 1/2	13/16	0.012	9042660079400	4266		
3/8	3/8	2 1/2	1	0.012	9042660095200	4266		
1/2	1/2	3 1/2	1 1/4	0.020			9042660127000	4266
5/8	5/8	3 1/2	1 1/4	0.020			9042660158700	4266
3/4	3/4	4	1 1/2	0.020			9042660190500	4266
1	1	4	1 1/2	0.031			9042660254000	4266

METRIC

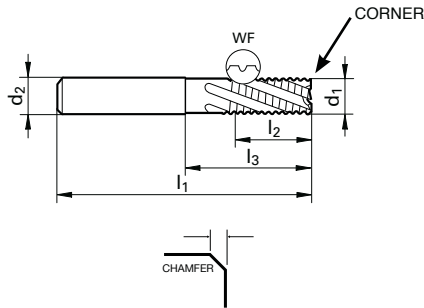

Includes Series

METRIC

3468

3469

3470

3471

Diameter	Shank Diameter	OAL	LOC	Reach	Corner	HA		HB	
						EDP No.	Series Number	EDP No.	Series Number
6.0	6.0	57	13	21	0.30	9034680060000	3468	9034690060000	3469
6.0	6.0	65	13	29	0.30	9034700060000	3470	9034710060000	3471
8.0	8.0	63	19	27	0.30	9034680080000	3468	9034690080000	3469
8.0	8.0	75	19	39	0.30	9034700080000	3470	9034710080000	3471
10.0	10.0	72	22	32	0.30	9034680100000	3468	9034690100000	3469
10.0	10.0	80	22	40	0.30	9034700100000	3470	9034710100000	3471
12.0	12.0	83	26	38	0.50	9034680120000	3468	9034690120000	3469
12.0	12.0	93	26	48	0.50	9034700120000	3470	9034710120000	3471
16.0	16.0	92	32	44	0.50	9034680160000	3468	9034690160000	3469
16.0	16.0	108	32	60	0.50	9034700160000	3470	9034710160000	3471
20.0	20.0	104	38	54	0.50	9034680200000	3468	9034690200000	3469
20.0	20.0	126	38	76	0.50	9034700200000	3470	9034710200000	3471
25.0	25.0	121	45	65	0.60	9034680250000	3468	9034690250000	3469

\* Indicates reduced neck style