

FRACTIONAL

AERO-ROUGH 56 RS100 F

FIREX® Coated, rougher, 5/6-flute

Includes Series
INCH
3098

TYPE	NF
HELIX ANGLE	45°
NUMBER of TEETH	5/6

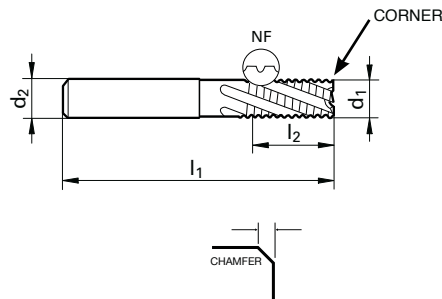

d_1 tolerance h10
 d_2 tolerance h6
 See table on page 150

Diameter	Shank Diameter	OAL	LOC	Corner		HA	
(d1) Frac	(d2) Frac	(l1) Frac	(l2) Frac	Chamfer Inch	Flutes	EDP No.	Series Number
1/4	1/4	2 1/2	3/4	0.012	5	9030980063500	3098
5/16	5/16	2 1/2	13/16	0.012	5	9030980079400	3098
3/8	3/8	2 1/2	7/8	0.012	5	9030980095200	3098
1/2	1/2	3	1	0.020	5	9030980127000	3098
5/8	5/8	3 1/2	1 1/4	0.020	6	9030980158700	3098
3/4	3/4	4	1 5/8	0.020	6	9030980190500	3098
1	1	4	1 3/4	0.031	6	9030980254000	3098

METRIC

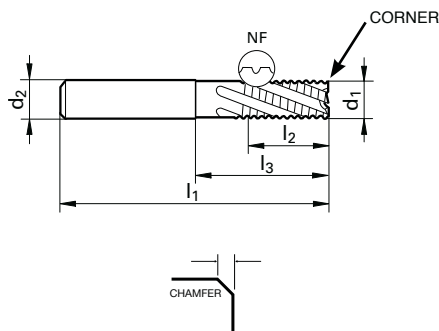

Includes Series
METRIC
3889
3890

Diameter	Shank Diameter	OAL	LOC	Reach			HA		HB	
(d1) mm	(d2) mm	(l1) mm	(l2) mm	* (l3) mm	Chamfer mm	Flutes	EDP No.	Series Number	EDP No.	Series Number
6.0	6.0	57	13	21	0.30	5	9038890060000	3889	9038900060000	3890
8.0	8.0	63	19	27	0.30	5	9038890080000	3889	9038900080000	3890
10.0	10.0	72	22	32	0.30	5	9038890100000	3889	9038900100000	3890
12.0	12.0	83	26	38	0.50	5	9038890120000	3889	9038900120000	3890
14.0	14.0	83	26	38	0.50	5	9038890140000	3889	9038900140000	3890
16.0	16.0	92	32	44	0.50	6	9038890160000	3889	9038900160000	3890
18.0	18.0	92	32	44	0.50	6	9038890180000	3889	9038900180000	3890
20.0	20.0	104	38	54	0.50	6	9038890200000	3889	9038900200000	3890
25.0	25.0	121	45	65	0.60	6	9038890250000	3889	9038900250000	3890

* Indicates reduced neck style