

# EXCLUSIVELINE®

## RT 100 T – special tools for MQL machining

### Special shank: RT 100T drills for minimum quantity lubrication (MQL)

For minimum quantity lubrication RT 100T drills are available with a special shank end optimised for MQL machining.

As only an extremely small amount of coolant is applied for minimal lubrication, the delivery of the coolant to the most effective location is of extreme importance. The tapered shank end, developed by Guhring, optimally satisfies the conditions relevant for

minimal lubrication applications: It prevents neat oil from consolidating and offers simple handling characteristics and cost-effective production. In combination with Guhring hydraulic expansion chucks and Guhring's MQL coolant delivery set, it offers an optimal and cost-effective solution for MQL machining with highest bore hole quality and outstanding lifetime.



Shank end suitable for minimal quantity lubrication without consolidation or dead pockets of coolant.

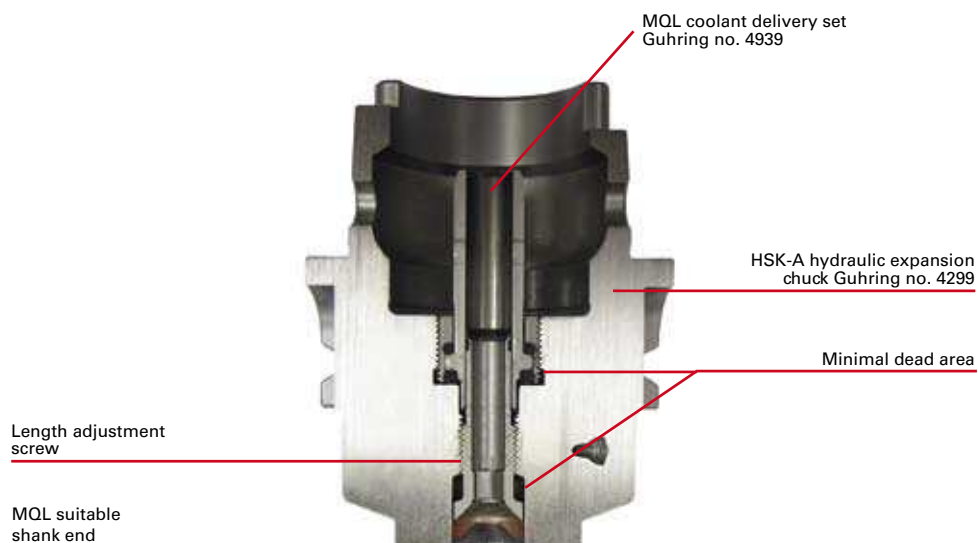

**The Guhring MQL system**  
A MQL optimised drilling tool with Guhring's MQL shank end is located in a hydraulic expansion chuck. The delivery of the coolant is realised by a MQL length adjustment screw with sealing lip.