

Solid carbide single-fluted gun drill EB 100 ex-stock range

Ex-stock range from Ø 1.2 to 8.0 mm,  
available with 45 and 160 mm flute length  
bright and SuperA-coated



EB 100



Since the introduction of the EB 100 ex-stock range, Guhring has successfully broken the rule that gun drills are special tools. This success gave us the incentive to expand the range continuously and be able to provide our customers with a greater choice of gun drills from stock.

In addition, HB or HE shank designs can be supplied with short notice within 10 days. We can naturally also produce any required gun drill as a special tool especially suited to your application from diameter 1.0 to 8.0 mm with max. flute lengths up to 300 mm.

All single-fluted gun drills EB 100 in the ex-stock range are supplied with head form G as well as a standard point geometry. The driver complies with DIN 6535 HA. Herewith, the tools in the ex-stock range cover a multitude of gun drill applications in a wide range of materials.

The dimensions required to calculate the length for conventional machine tools

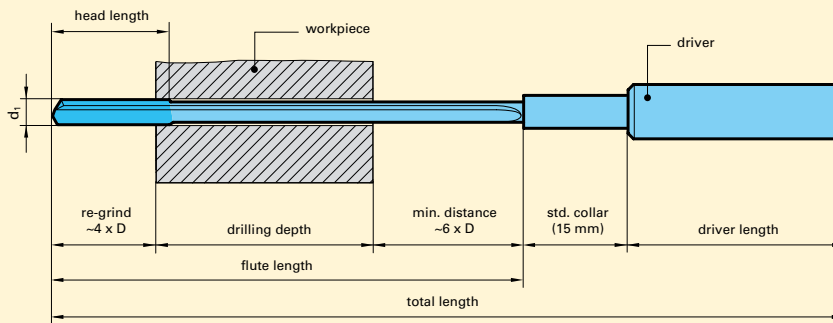

EB 100  
Head form

(Position of supporting strips.  
Special head forms available)

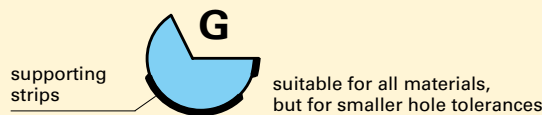

EB 100  
Standard point grind

(special point grinds on request)

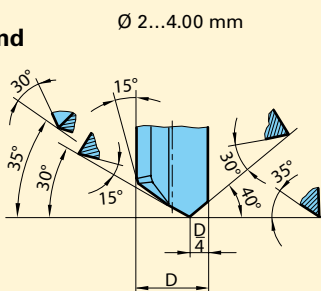

Ø 4.01...8 mm

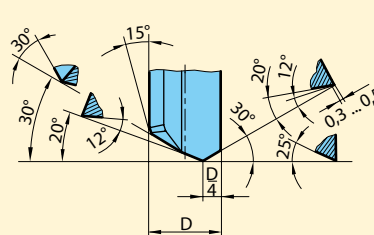

EB 100  
Back taper ratio

(dimensions in mm)

