

HT 800 WP Application Recommendations

All data are approximate values. The actually achievable cutting speeds and feed rates depend on the respective machining conditions. We recommend suitable drilling trials.

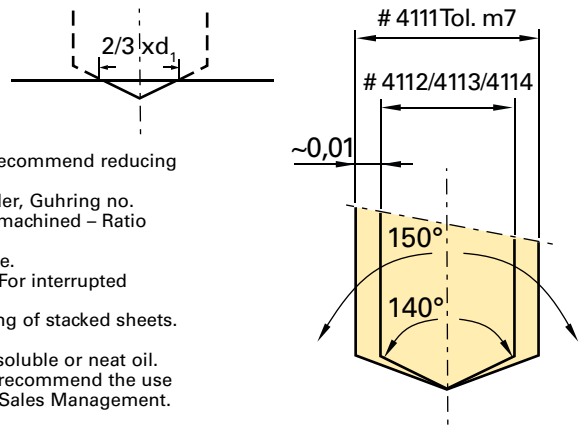

- for through holes supporting lands must remain in permanent contact. In addition, we recommend reducing the feed rate prior to exiting.
- for drilling depths from 5xD we generally recommend centring or pilot drilling with holder, Guhring no. 4105, and pilot insert, Guhring no. 4111. Alternatively – depending on the material to be machined – Ratio drills type RT 100 U or RT 100VA can be applied.
- for drilling without centring we recommend reducing the feed rate at the start of the hole.
- don't apply drilling tool without trial for interrupted cutting (grooves, transverse holes). For interrupted cutting (max. 0.2xD) it is recommended to reduce the feed rate whenever possible.
- in contrast to conventional indexable inserts, HT 800 WP are also suitable for the drilling of stacked sheets.
- on a lathe (stationary tool) it must be ensured that the tool is accurately centred.
- pre-condition for optimal machining results is a sufficient cooling lubricant supply with soluble or neat oil.
- the tool is only of limited suitability for dry machining or MQL. For MQL application we recommend the use of the conical MQL shank end as well as Guhring MQL components. Please contact our Sales Management.

Drill-Ø mm	Feed column no.								
	1	2	3	4	5	6	7	8	9
	f (mm/rev.)								
0.50	0.004	0.006	0.007	0.008	0.010	0.012	0.014	0.016	0.019
1.00	0.006	0.008	0.012	0.014	0.016	0.018	0.020	0.023	0.025
2.00	0.020	0.025	0.032	0.040	0.050	0.063	0.080	0.100	0.125
2.50	0.025	0.032	0.040	0.050	0.063	0.080	0.100	0.125	0.160
3.15	0.032	0.040	0.050	0.063	0.080	0.100	0.125	0.160	0.160
4.00	0.040	0.050	0.063	0.080	0.100	0.125	0.160	0.200	0.200
5.00	0.040	0.050	0.063	0.080	0.100	0.125	0.160	0.200	0.250
6.30	0.050	0.063	0.080	0.100	0.125	0.160	0.200	0.250	0.315
8.00	0.063	0.080	0.100	0.125	0.160	0.200	0.250	0.315	0.315
10.00	0.080	0.100	0.125	0.160	0.200	0.250	0.315	0.400	0.400
12.50	0.080	0.100	0.125	0.160	0.200	0.250	0.315	0.400	0.500
16.00	0.100	0.125	0.160	0.200	0.250	0.315	0.400	0.500	0.630
20.00	0.125	0.160	0.200	0.250	0.315	0.400	0.500	0.630	0.630
25.00	0.160	0.200	0.250	0.315	0.400	0.500	0.630	0.800	0.800
31.50	0.160	0.200	0.250	0.315	0.400	0.500	0.630	0.800	1.000

- Coolant:
- air
 - neat oil
 - soluble oil

Material group	Material examples, new description (old description in brackets) <i>Figures in bold = material no. to DIN EN</i>	Tensile strength MPa (N/mm ²)	Hard- ness	Cool- ant
Common structural steels	1.0035 S185(St33), 1.0486 P275N(StE285), 1.0345 P235GH(H1), 1.0425 P265GH(H2) 1.0050 E295 (St50-2), 1.0070 E360 (St70-2), 1.8937 P500NH (WStE500)	≤500 >500-850		○
Free-cutting steels	1.0718 11SMnPb30 (9SMnPb28), 1.0736 11SMn37 (9SMn36) 1.0727 46S20 (45S20), 1.0728 (60S20), 1.0757 46SPb20 (45SPb20)	≤850 850-1000		○
Unalloyed heat-treatable steels	1.0402 C22, 1.1178 C30E (Ck30) 1.0503 C45, 1.1191 C45E (Ck45) 1.0601 C60, 1.1221 C60E (Ck60)	≤ 700 700-850 850-1000		○
Alloyed heat-treatable steels	1.5131 50MnSi4, 1.7003 38Cr2, 1.7030 28Cr4 1.5710 36NiCr6, 1.7035 41Cr4, 1.7225 42CrMo4	850-≤1000 1000-1200		○
Unalloyed case hardened steels	1.0301 (C10), 1.1121 C10E (Ck10)	≤750		○
Alloyed case hardened steels	1.7043 38Cr4 1.5752 15NiCr13 (15NiCr13), 1.7131 16MnCr5, 1.7264 20CrMo5	850-≤1000 1000-1200		○
Nitriding steels	1.8504 34CrAl6 1.8519 31CrMoV9, 1.8550 34CrAlNi7	≥850-≤1000 >1000-1200		○
Tool steels	1.1750 C75W, 1.2067 102Cr6, 1.2307 29CrMoV9 1.2080 X210Cr12, 1.2083 X42Cr13, 1.2419 105WCr6, 1.2767 X45NiCrMo4	≤850 >850-1000		○
High speed steels	1.3243 S 6-5-2-5, 1.3343 S 6-5-2, 1.3344 S 6-5-3	≥650-1000		○
Spring steels	1.5026 55Si7, 1.7176 55Cr3, 1.8159 51CrV4 (51CrV4)		≤330 HB	○
Stainless steels, sulphured austenitic martensitic	1.4005 X12CrS13, 1.4104 X14CrMoS17, 1.4105 X6CrMoS17, 1.4305 X8CrNiS18-9 1.4301 X5CrNi18-10 (V2A), 1.4541 X6CrNiTi18-10, 1.4571 X6CrNiMoTi 17-12-2 (V4A) 1.4057 X20CrNi 17 2 (X17CrNi16-2), 1.4122 X39CrMo17-1, 1.4521 X2CrMoTi18-2	≤850 ≤850 ≤850		○
Hardened steels	-		≤40-48 HRC >48-60 HRC	○
Special alloys	Nimonic, Inconel, Monel, Hastelloy	≤1200		○
Cast iron	0.6010 EN-GJL-100(GG10), 0.6020 EN-GJL-200(GG20) 0.6025 EN-GJL-250(GG25), 0.6035 EN-GJL-350(GG35)		≤240 HB <300 HB	○
New cast materials CGI	EN-GJV250 (GGV25), EN-GJV350 (GGV35) EN-GJV400 (GGV40), EN-GJV500 (GGV50), SiMo 6		≤220 HB <300 HB	○
New cast materials ADI	EN-GJS-800-8 (ADI800), EN-GJS-1000-5 (ADI1000) EN-GJS-1200-2 (ADI1200), EN-GJS-1400-1 (ADI1400)	800-1000 1200-1400		○
Spheroidal graphite iron and malleable cast iron	0.7050 EN-GJS-500-7(GGG50), 0.8035 EN-GJMW-350-4(GTW35) 0.7070 EN-GJS-700-2(GGG70), 0.8170 EN-GJMB-700-2(GTS70)		≤240 HB <300 HB	○
Chilled cast iron	-		≤350 HB	○
Ti and Ti-alloys	3.7024 Ti99,5, 3.7114 TiAl5Sn2,5, 3.7124 TiCu2 3.7154 TiAl6Zr5, 3.7165 TiAl6V4, 3.7184 TiAl4Mo4Sn2,5, -TiAl8Mo1V1	≤850 >850-1200		○
Aluminum and Al-alloys	3.0255 Al99,5, 3.2315 AlMgSi1, 3.3515 AlMg1 3.0615 AlMgSiPb, 3.1325 AlCuMg1, 3.3245 AlMg3Si, 3.4365 AlZnMgCu1,5	≤400 ≤450		○
Al cast alloys ≤ 10 % Si > 10 % Si	3.2131 G-AlSi5Cu1, 3.2153 G-AlSi7Cu3, 3.2573 G-AlSi9 3.2581 G-AlSi12, 3.2583 G-AlSi12Cu, - G-AlSi12CuNiMg	≤600 ≤600		○
Magnesium alloys	3.5200 MgMn2, 3.5812.05 G-MgAl8Zn1, 3.5612.05 G-MgAl6Zn1	≤450		○
Copper, low-alloyed	2.0070 SE-Cu, 2.1020 CuSn6, 2.1096 G-CuSn5ZnPb	≤400		○
Brass, short-chipping long-chipping	2.0380 CuZn39Pb2, 2.0401 CuZn39Pb3, 2.0410 CuZn43Pb2 2.0250 CuZn20, 2.0280 CuZn33, 2.0332 CuZn37Pb0,5	≤600 ≤600		○
Bronze, short-chipping	2.1090 CuSn7ZnPb, 2.1170 CuPb5Sn5, 2.1176 CuPb10Sn 2.0790 CuNi18Zn19Pb	≤600 >600-850		○
Bronze, long-chipping	2.0916 CuAl5, 2.0960 CuAl9Mn, 2.1050 CuSn10 2.0980 CuAl11Ni, 2.1247 CuBe2	≤850 >850-1000		○