

H Cartridges

with tapered screw adjustment, μm -accurate adjustable

90° approach angle

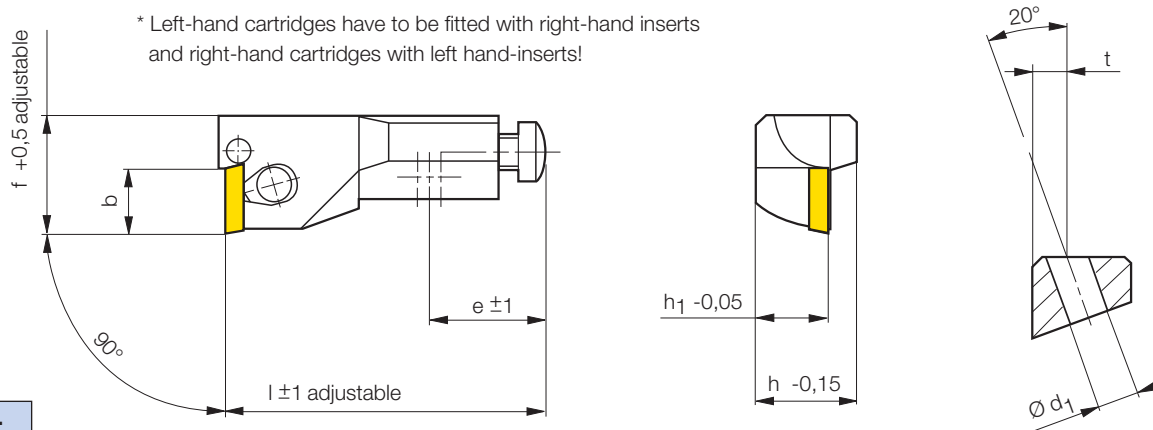

Part nr. 20040											
Code	Drawing nr.		b	f	l	e	h ₁	h	t	d ₁	Inserts*
8,000	H 1035-2088 0890 R CBFP R 06 CA-04	●	3.9	8	25	12	6	8.5	3.5	4	W 1035-... L
10,000	H 2850-2588 1090 R CBFP R 08 CA-05	●	5	10	32	17	8	11	4.5	4.5	W 2850-... L
12,000	H 3570-3088 1290 R CBFP R 08 CA-07	●	7	12	40	17	8	11	4.5	4.5	W 357-... L
14,000	H 4090-3588 1490 R CBFP R 10 CA-09	●	9	14	50	20	10	14	5	7	W 409-... L

H 3570-3088 1290 R/L are not included in the ISO-Norm

Part nr. 20041											
Code	Drawing nr.		b	f	l	e	h ₁	h	t	d ₁	Inserts*
8,000	H 1035-2088 0890 L CBFP L 06 CA-04	○	3.9	8	25	12	6	8.5	3.5	4	W 1035-... R
10,000	H 2850-2588 1090 L CBFP L 08 CA-05	○	5	10	32	17	8	11	4.5	4.5	W 2850-... R
12,000	H 3570-3088 1290 L CBFP L 08 CA-07	○	7	12	40	17	8	11	4.5	4.5	W 357-... R
14,000	H 4090-3588 1490 L CBFP L 10 CA-09	○	9	14	50	20	10	14	5	7	W 409-... R

● ex stock ○ on request

Ordering example: 1 piece H 1035-2088 0890 R = Ordering number: 20040 8,000



Spare parts
page 72