

H Cartridges

with tapered screw adjustment, μm -accurate adjustable

Spare parts

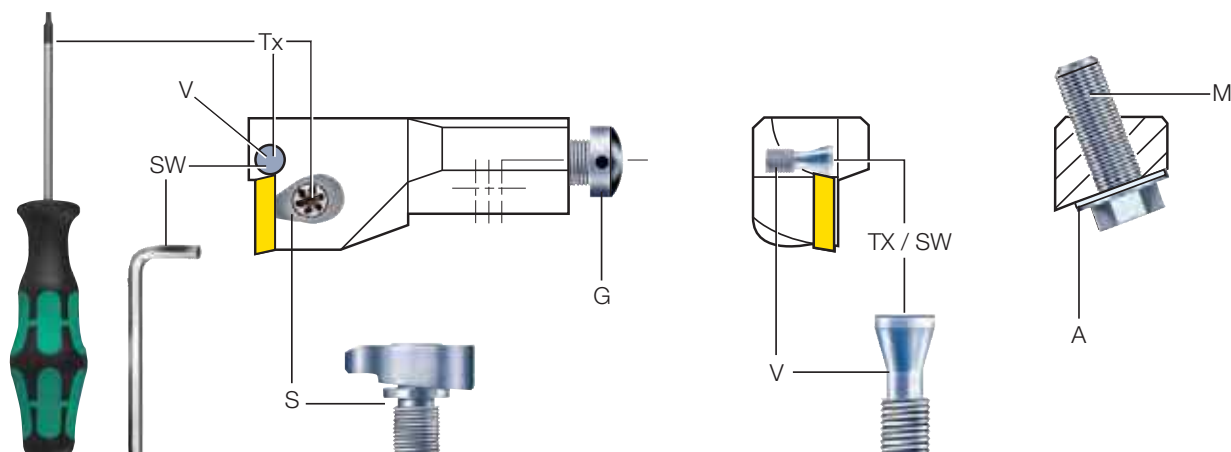

Tool	S	Tx	V	Tx / SW	G	M	A
H 1035-2088 0890 R	E 1100	Tx 5	E 3007	Tx 5	E 2611-1	E 2613-1	E 2619-2
H 1035-2088 0890 L	E 1120	Tx 5					
CBFP R/L 06 CA-04							
H 2850-2588 1090 R/L	E 1112	Tx 6	E 2986	Tx 6	E 2611-2	E 2613-2	E 2619-2
CBFP R/L 08 CA-05							
H 3570-3088 1290 R/L	E 1060	Tx 8	E 3093	SW 1,3	E 2611-2	E 2613-2	E 2619-2
CBFP R/L 08 CA-07							
H 4090-3588 1490 R/L	E 1040	Tx 15	E 2997	SW 1,5	E 2611-3	E 2613-3	E 2619-3
CBFP R/L 10 CA-09							

Please note: Clamping set S contains:

1 clamping element, 1 retainer ring, 1 clamp screw

S	Clamping set
Tx	Torx-screw driver (for operating clamping and adjustment screw)
V	Adjustment screw (tapered screw)
SW	Hexagon socket screw key
M	Fastening screw
G	Axial adjustment screw
A	Disk

Ordering numbers for spare parts see page 127-129