

Application examples

Application: Machining of balancer shaft bores

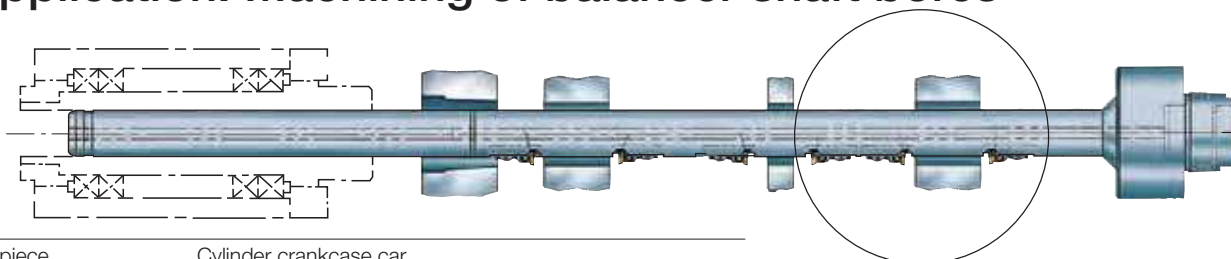

Workpiece	Cylinder crankcase car
Material	Al Si 9 Cu 3
Tool	Line boring bar with cartridges roughing and finishing, 3 pillow blocks
Insert	W 1035-0400 0000 R und L
Cutting grade	PCD
Cutting speed	$V_C = 280$ m/min
Feed rate per tooth	$f = 0.08$ mm/rev. ($\nabla\nabla$) $f = 0.12$ mm/rev. (∇)
Internal cooling	yes

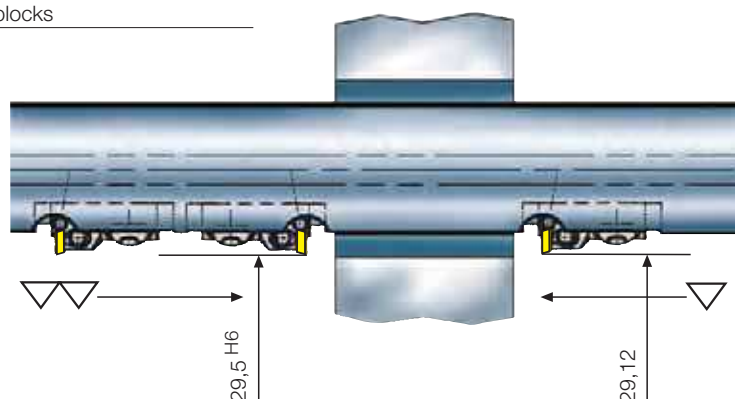

Application: Machining of valve seats

Workpiece	Cylinder head car
Material	Al Si 10
Tool	Multistep fineboring tool with carbide shank
Insert	W 2850-..... L with wiper geometry
Cutting grade	PCD
Cutting speed	$V_C = 300$ m/min
Feed rate	$f = 0.1$ mm/U
Internal cooling	yes

