

HPC milling cutters

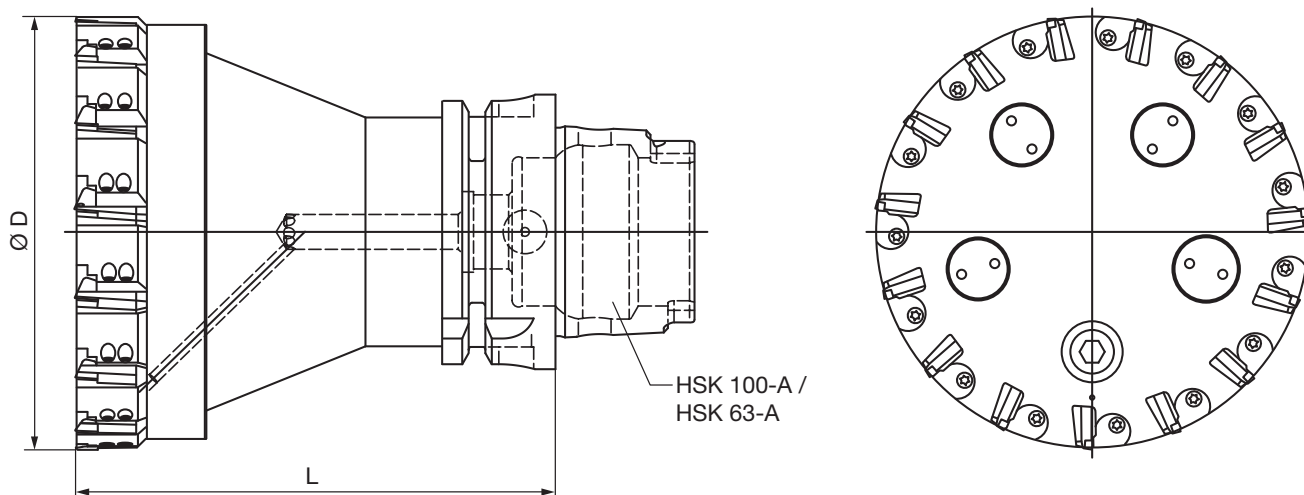

Standard range with a reduced number of cutting edges
for cutting depths up to max. 2 mm



Part nr. 20004							
Code	Drawing nr.	Diameter/mm	cutting edges	L/mm	max. rev./min	Shank	Weight (kg)
for lower spindle power							
63,106	Q 9933-6300 1063 R	63	9	100	31,000	HSK 63-A	1.9
80,106	Q 9933-8000 1163 R	80	12	110	28,000	HSK 63-A	2.7
100,106	Q 9933-1000 1163 R	100	15	110	24,000	HSK 63-A	3.7
125,106	Q 9933-1250 1263 R	125	18	123	20,000	HSK 63-A	5.5
160,106	Q 9933-1600 1263 R	160	24	123	15,000	HSK 63-A	7.7

Part nr. 20004							
Code	Drawing nr.	Diameter/mm	cutting edges	L/mm	max. rev./min	Shank	Weight (kg)
for lower spindle power							
63,108	Q 9933-6300 1010 R	63	9	100	31,000	HSK 100-A	3.2
80,108	Q 9933-8000 1110 R	80	12	110	28,000	HSK 100-A	4.2
100,108	Q 9933-1000 1110 R	100	15	110	24,000	HSK 100-A	5.7
125,108	Q 9933-1250 1210 R	125	18	123	20,000	HSK 100-A	7.7
160,108	Q 9933 -1600 1210 R	160	24	123	15,000	HSK 100-A	10

Ordering example: 1 piece Q 9933-6300 1010 R = Ordering number: 20004 63,108

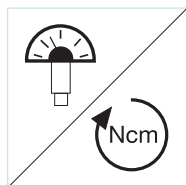

Adjustment instruction page 11



Form „Request for customer specific tools“ page 131

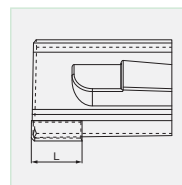

PCD inserts page 10